

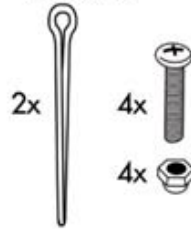

Hand Truck

CONWIN Assembly Instructions

Includes:



Required:



1 Attach the Wheels

Slide axel into wheel support bracket on base of hand truck, and place wheels on axel with the extended side of the hub facing inward.

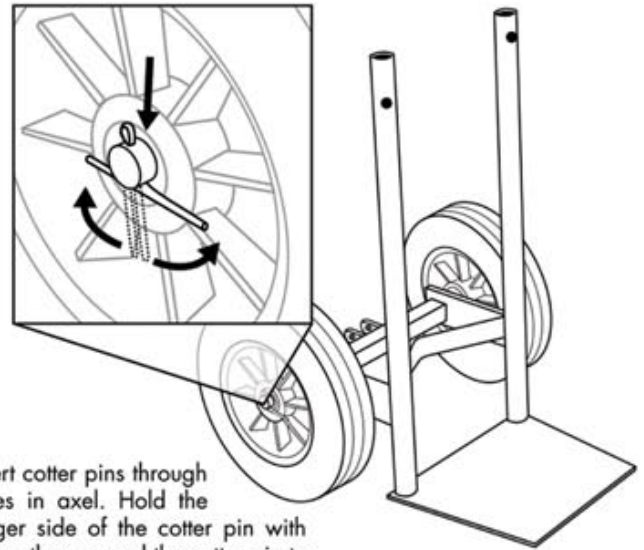
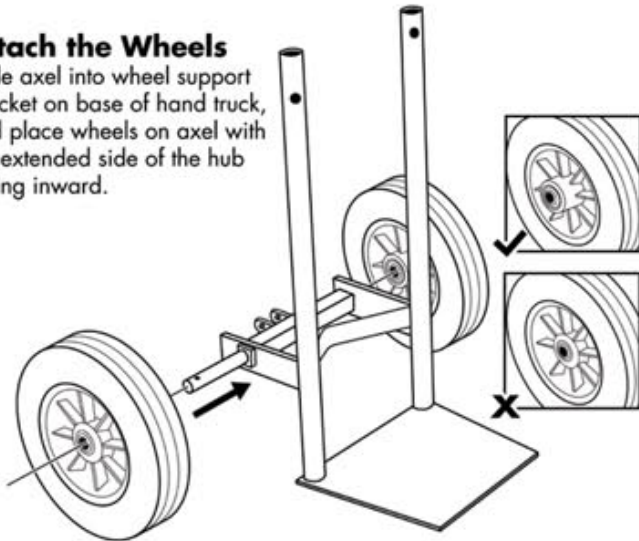

2 Insert cotter pins through holes in axel. Hold the longer side of the cotter pin with pliers, then spread the cotter pin to secure wheels in place.

Safety Tip: Bend the tails of cotter pin inward toward the wheel to avoid harm.

3 Connect Base and Upper Section of Hand Truck

Insert support connectors into base of hand truck. Align the holes.

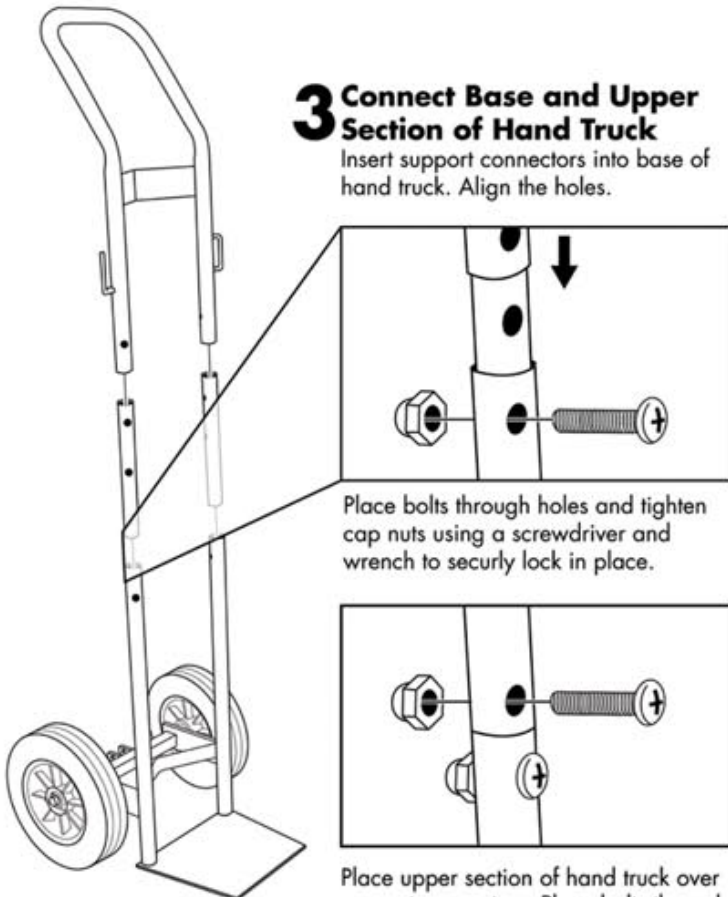

Place bolts through holes and tighten cap nuts using a screwdriver and wrench to securely lock in place.

Place upper section of hand truck over support connectors. Place bolts through holes and tighten cap nuts.

4 Slide Velcro® belt over hook on side of hand truck.

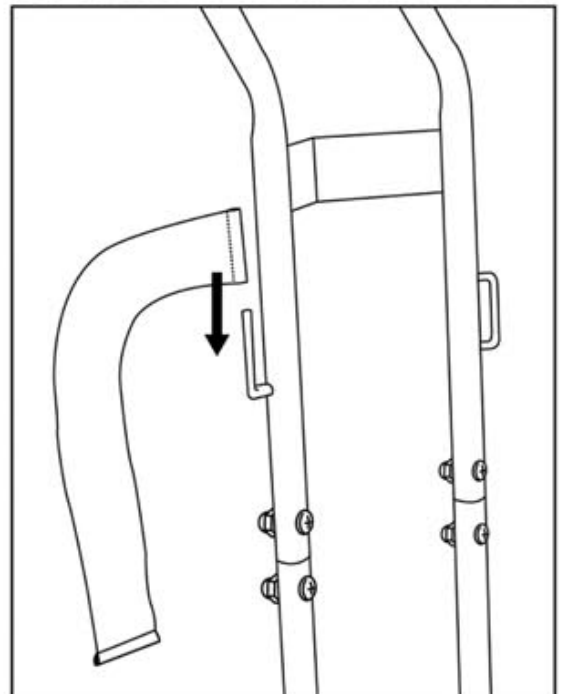



2-Wheel Add-On Carriage

Assembly Instructions

Includes:

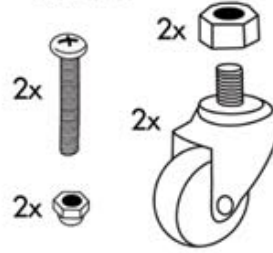

Required:

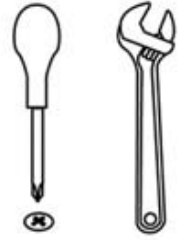

*Hand Truck Accessory Item - Sold Separately.

1 Attach the Wheels

Slide wheels through carriage and tighten nut onto wheel bolt using a wrench to securely lock in place.

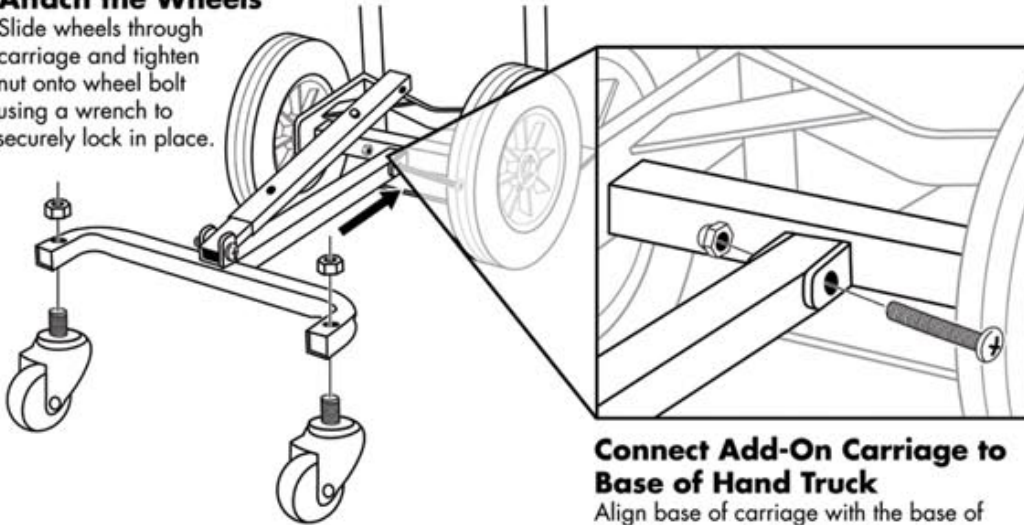

Connect Add-On Carriage to Base of Hand Truck

Align base of carriage with the base of hand truck, and place bolt through holes. Tighten nut using a screwdriver and wrench.



The rear wheel carriage folds up to enable ease in transporting the hand truck to the job and allows user to move cylinders up and down stairs.

2 Extend Carriage Support

Push the release button to raise the Add-On Carriage extension. Make sure the release button locks into the second setting hole to secure the rear wheel carriage in the fully extended position.

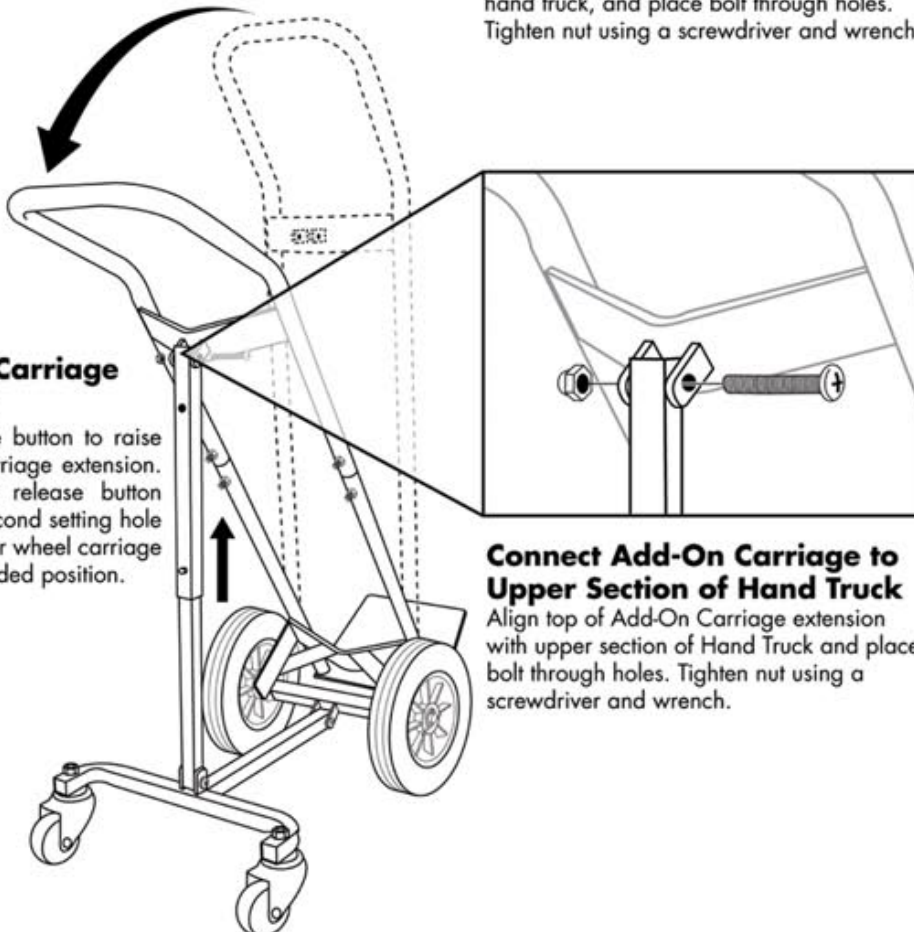

Connect Add-On Carriage to Upper Section of Hand Truck

Align top of Add-On Carriage extension with upper section of Hand Truck and place bolt through holes. Tighten nut using a screwdriver and wrench.



Attach the balloon inflator to the cylinder parallel with the handle of the hand truck. The 4-Wheel Hand Truck doubles as a safety stand when in the tilt-back position.



CONWIN Inc.
Los Angeles, CA 90039

061011

Service & Warranty

For assistance with service & repair issues, or for warranty information, please visit ConwinOnline.com or call (818) 246-9233

© 2011 CONWIN Inc.